

BID SPECIFICATION BN-9057001808/(2018-19)

(UBN NO. – VPN1819GSOB02667)

FOR PURCHASE & INSTALLATION OF 2 NO'S OF KITCHEN CHIMNEY AND 1 NO'S BAIN MARIE (5+2- FOOD WARMER) AT THE KITCHEN OF OFFICER'S TRAINING HOSTEL UNDER THE OFFICE OF XEN(TRG.), RVPN,JMC BUILDING, BANI PARK JAIPUR-3020006.

SCOPE

This specification covers the size and quality of material and terms and conditions for bidders for purchase and installation of kitchen chimney and Bain Marie (5+2-Food Warmer) at the Officer's training hostel near Ram Mandir, Bani Park, Jaipur under the office of Xen(Trg.),RVPN, JMC Building, Bani Park, Jaipur.

1. TERMS & CONDITIONS:-

- (i) The procurement process shall be governed by RTPP Act,2012 and RTPP Rules, 2013 as amended.
- (ii) The procurement is being done through single stage open competitive bidding.
- (iii) RVPN does not bind itself to accept the lowest or any other bid and reserve the right to reject any or all bid(s) without assigning any reason thereof.
- (iv) RVPN reserves the right to award this work wholly or partly to any other contractor also.
- (v) RVPN reserves the right to terminate the contract at any time by giving 15 days notice in writing without assigning any reason thereof and without any compensation.
- (vi) In case of any violation of Terms & Conditions of contract or unsatisfactory service/performance, RVPN reserves the right to terminate the contract by giving 15 days notice to the contractor.
- (vii) The bid cost Rs. 750/-+GST @ 18%(non-refundable) and bid security Rs. 4000/- (Four Thousand) shall be deposited by crossed demand draft/Banker's cheque in the name of Sr. Accounts Officer (EA&Cash), RVPN, Jaipur. **No interest shall be paid on any deposits.**
- (viii) Conditional bids shall not be accepted and such Bids shall be rejected summarily.

2. BID SECURITY:-

- (i) Bid security Rs. 4000/- (Four Thousand) shall be deposited by crossed demand draft/Banker's cheque in the name of Sr. Accounts Officer (EA&Cash), RVPN, Jaipur. No interest shall be paid on any deposits.
- (ii) The bid security of unsuccessful bidders shall be refunded soon after final acceptance of successful bid and signing of Agreement and submitting

Handwritten signature and initials

performance security. In case of successful bidders, the amount of bid security may be adjusted in arriving at the amount of the Performance Security at his will, or refunded if the successful bidder deposits the full amount of Performance Security.

- (iii) RVPN reserves the right to forfeit bid security or a part thereof in circumstance, which according to it indicate that the bidder is not earnest in accepting/executing any order placed under the specification and under following conditions:-
- (i) When the bidder withdraws or modifies its bid after opening of bids.
 - (ii) When the bidder does not execute the agreement, if any, after placement of work order within the time specified.
 - (iii) When the bidder fails to commence the service or execute work as per work order within the time specified.
 - (iv) When the bidder does not deposit the performance security within specified period after the work order is placed.
 - (v) If the bidder breaches any provision of code of integrity prescribed for bidders specified in the RTPP Act/Rules.

3. The rate shall be quoted in the format of BOQ BN-9057001808/ (2018-19), attached herewith including the GST.
4. **The bid evaluated as lowest in total amount quoted in BOQ will be considered for award of contract.**
5. The Bid shall remain valid for 90 days from the date of bid opening or as per extension, if any, thereof.
6. All legal deductions such as income tax (TDS) etc. (if any applicable) shall be made as per Law/Rules applicable at the time of payment.

7. TERMS OF PAYMENT :-

- (i) Any payment under this Bid shall only be made after submission of all contractual formalities i.e. Contract Agreement, Security Deposit, and Performance Guarantee by the Service Provider and the acceptance of the same by Nigam.
- (ii) 100 % Payment after complete installation shall be admissible on receipt of bill complete in all respect, in triplicate and deposition of Performance security from the successful bidder duly verified/certified by Engineer-In-charge within 30 days.

8. PERFORMANCE SECURITY DEPOSIT:-

- (i) The successful bidder shall have to furnish performance security @5% of the awarded total contract value.
- (ii) Performance security shall be submitted/ deposited by successful bidder in the form of Demand Draft/Banker's cheque in the name of Sr. Accounts Officer (EA&Cash), RVPN, Jaipur within fifteen (15) days from the date of issue of the order. After depositing the performance security @ 5% and signing of the contract, the Bid security deposit will be refunded to the contractor.
- (iii) The bid security deposit may be adjusted towards performance security deposit@5% and balance amount of performance security shall be deposited in the office of the Sr. AO (EA&Cash), RVPN, Jaipur.
- (iv) **If, bidder fails to deposit the amount of performance security deposit as above, then the 5% of the total bill shall be retained as performance security**

[Handwritten signature]

deposit upto 5% of contract value in addition to BID SECURITY amount and both shall be refunded after completion of contract/warranty successfully.

- (v) The performance security will be refunded after successful completion of the contract/ warranty period.
- (vi) No interest shall be payable on performance security deposit.

9. CONTRACT AGREEMENT:-

The contract agreement on non-judicial stamp paper as per Stamp duty applicable of Govt. of Rajasthan will be furnished by you as per prescribed format to abide by the Terms and Conditions of the contract which shall be signed by both parties before any payment.

10. Documents to be submitted with Bid :-

- (i) GST Registration Number certificate of the bidder.
- (ii) The firm/contractor should have completed two or more similar work of each value Rs. 2 lakh or more in any Govt. Office or University or hotel/PSU's etc. in last 3 years. Self Attested copies of work order given by the bidder is to be submitted.
- (iii) In case of manufacturer License (**TIN NUMBER**) / GST Registration certificate from respective agency of State or Central Govt. Regarding manufacturing of kitchen appliances.
- (iv) In case of dealer authorisation certificate from the manufacturer company for selling of kitchen appliances.

11. DISPUTE:-

Any dispute arising out of the contract shall be subject to the jurisdiction of court at Jaipur (City) Rajasthan only.

12. LIABILITY FOR ACCIDENTS AND DAMAGES:-

The contractor shall be entirely responsible for all loss, damage or depreciation of equipment/any other material/building premises etc. caused due to their negligence until the complete installation of kitchen chimney and Bain Marie work is taken over by the Nigam.

14. Warranty:-

The Contractor should give minimum 1 year warranty on the equipments installed in Kitchen Chimney and Bain Marie (Food Warmer-5+2) from the date of installation, if any of the equipments is found defective within one(1) year then the contractor should replace it at its own cost.

15. The Executive Engineer (Trg.) reserves the right to accept or reject any Bid without assigning any reason.

Per Sir S. S. S.

16. Detailed specification of parts which will be in use for making of kitchen chimney is under the table below :-

| Sr. NO. | Equipment Name | Specifications of the Material | Over all size (INCHES)/STANDARD | Quantity |
|---------|--|---|---|----------|
| 1 | Providing and fixing " EXHAUST STAINLESS STEEL HOOD with Baffle type filter with oil collector tray or mechanism with matt finish. | Stainless Steel hood should be made of 18 guage sheet of 304 grade steel and for Baffle type filter Stainless Steel Should be of 18 guage and 304 grade steel | (48"X36"X18") and (72"X36"X18") | 2 |
| 2 | Rectangular Duct | Galavionised Iron Sheet with 120 gsm of Zinc of branded Company | 255 square foot and 0.60 mm thick minimum | 1 |
| 3 | Exhaust Fan | 1 Horse Power | ISI MARK and 24 Inch in size and 1400 RPM | 1 |
| 4 | Mild Steel Jali | As per fitting of Exhaust Hood | ISI MARK | 1 |

17. Detailed specification of parts which will be in use for making of Bain Marie (5+2- Food Warmer) is as follows:-

(i) Over all size of Bain Marie (5+2- Food Warmer) :- (96 x 27+12 x 34) Inches.

(ii) Specification and material for Bain Marie :-

- It should include 7 nos. of Gastronorm Pans 1/1 size(530X325x200)mm.
- Table top water tank will be made up of 16 guage Stainless Steel.
- Underneath support structure made by 304 Stainless Steel Angle/ SS square pipe. Four vertical legs will be made by 40 mm dia SS pipe 304 grade with nylon adjustable bullets.

Subal Sison

- One bottom shelf, made of 18 swg Stainless Steel 304 grade stainless steel sheet, is to be provided at a height of six (6) inches from ground.
- Water Tank, Outer Panel to be made of 16 swg Stainless Steel 304 grade stainless steel sheet.
- Tank will have glasswool insulation. of 50mm between 5 hot and 2 GN pans.
- Tray sliding sheet (12 inch wide) will be made of 18 swg Stainless Steel 304 grade. It will be supported for rigidity at appropriate locations by 1 Inch" inch Stainless Steel square/round pipe.
- External visible portion of Stainless Steel sheets will be matt finished.
- There shall be provision for proper water inlet and outlet arrangement.
- Electrical heating arrangement by ISI marked Immersion Heater at multiple points coupled with thermostatic control.
- Electric Load-3 Kw(1.5 KW DIFFERENT CONNECTIONS), 220V, A.C., single phase. Industrial grade ON/ OFF switch.

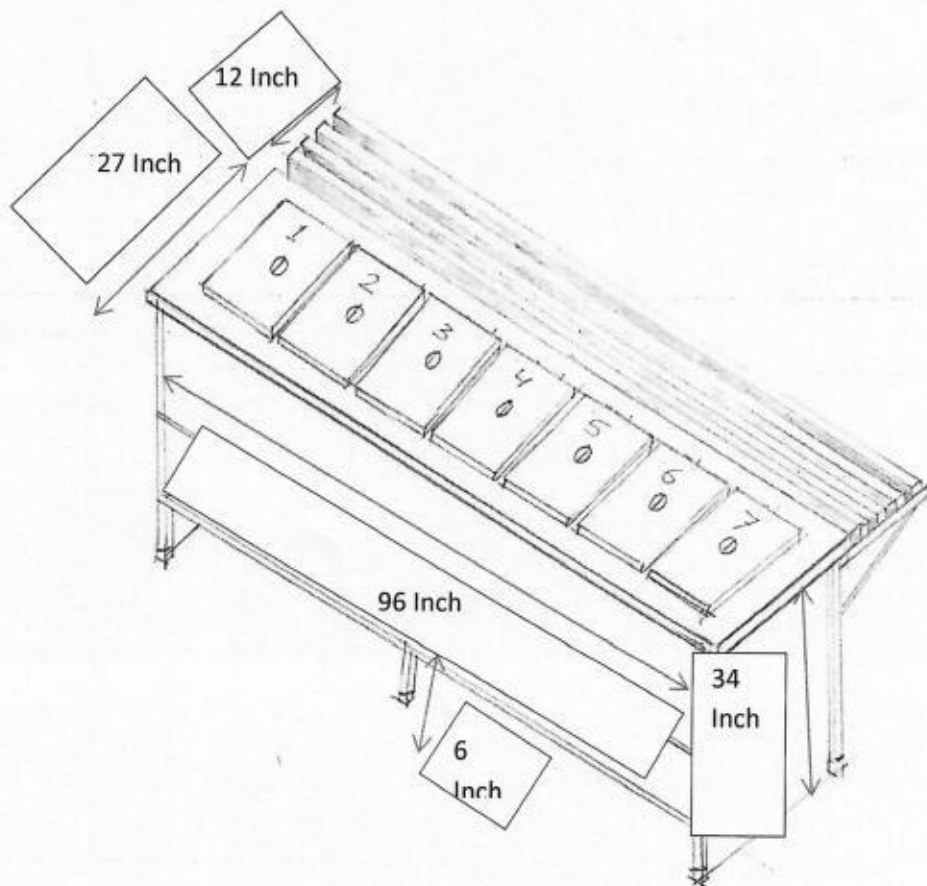

REFRENC PIC OF BAIN MARIE (5+2 FOOD WARMER)

Ru Sita. Saha

BOQ BN-9057001808/(2018-19)

(UBN NO. – VPN1819GSOB02667)

BOQ FOR PROVIDING AND INSTALLATION OF KITCHEN CHIMNEY AND BAIN MARIE (5+2-FOOD WARMER) MUST BE FILLED BY THE BIDDER AND ENCLOSED WITH THE BID.

| Sr NO | Particular specification and Quality and Standard as pr clauses of Bid Specification | Qty. | GST % | Unit Rate Without GST (In Rs.) | Unit rate GST Amount (In Rs.) | Total quoted Amount with GST |
|-------|--|------|-------|--------------------------------|-------------------------------|------------------------------|
| 1 | 2 | 3 | 4 | 5 | 6 | 7 =(5+6) |
| 1 | As per Clause No. 16 of Bid Specification for installing kitchen Chimney | 2 | | | | |
| 2 | As per clause No. 17 for Bain Marie (5+2-Food Warmer) | 1 | | | | |
| 3 | Installation Charges for both Kitchen Chimney and Bain Marie (5+2-Food Warmer) | NA | | | | |
| 4 | Transportation Charges for both Kitchen Chimney and Ban Marie (5+2-Food Warmer) | NA | | | | |
| 5 | TOTAL QUOTED AMOUNT FROM (Sr.No. 1 to Sr. No.4) | | | | | |

NOTE:- TIME PERIOD FOR WORK COMPLETION WILL BE 30 DAYS AND WARRANTY ON THE KITCHEN CHIMNEY AND BAIN MARIE (5+2-FOOD WARMER) WILL BE MINIMUM 1 YEAR FROM THE DATE OF INSTALLATION.

Name of bidder -

Mobile No. -

GST registration No.: -

Address -

Signature of bidder with seal

Full Signature